

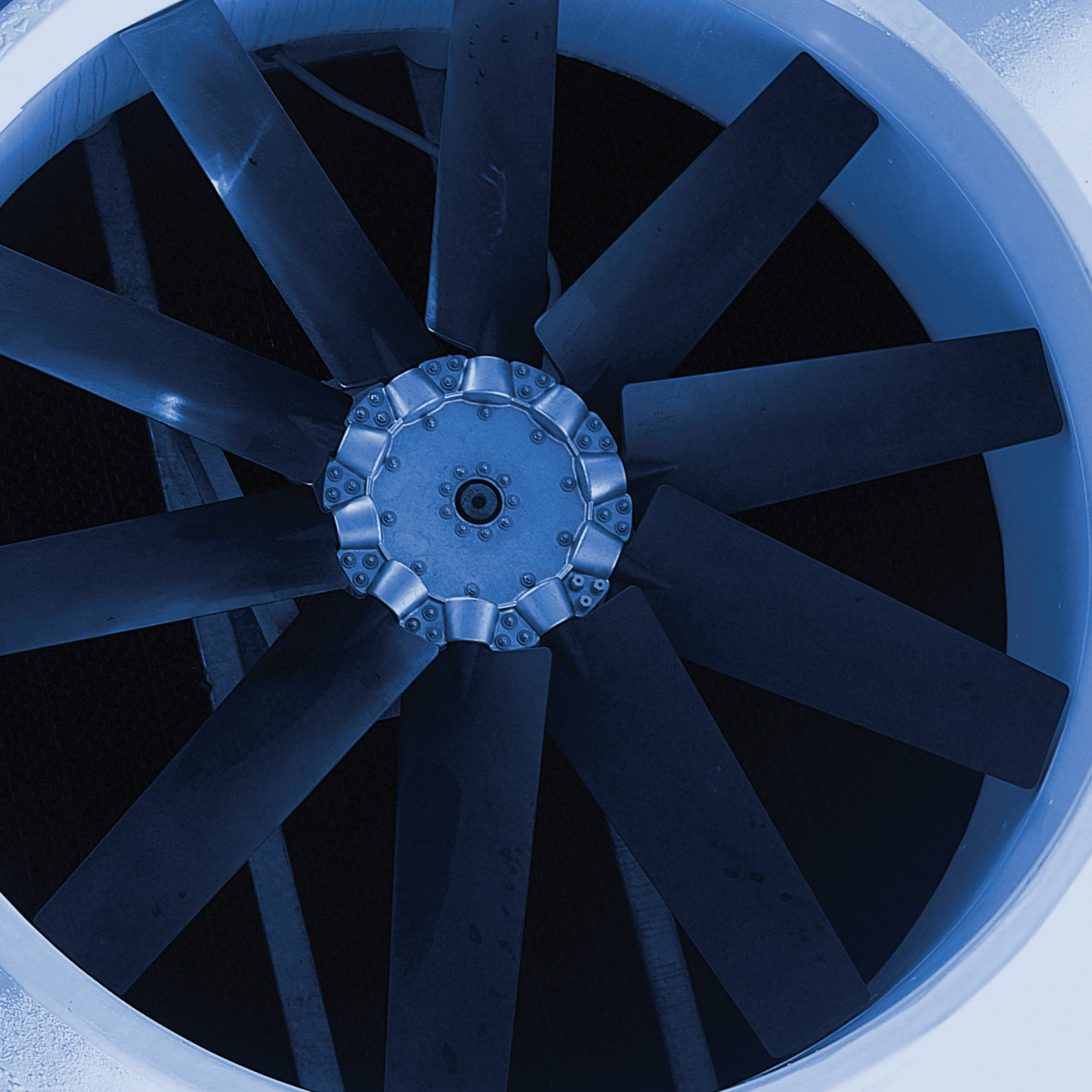

Processor 

Vestas industrial cooling

Induced draft wet cooling towers



The efficient solution

Nature's own method

Open-circuit cooling towers offer the most cost effective and most natural method for cooling water. That is because nature itself creates the cooling effect. In an open circuit, water flows against an airflow down a liner with a large surface area. By this direct contact between water and air, a small amount of water evaporates, thereby cooling the remainder of the water circulated. The cooling water may typically be cooled below surrounding air temperature.

Multiple applications

Cooling towers may be used to great advantage in industries using cooling water e.g. in process cooling, cooling of condensers, hydraulic oil, autoclaves, evaporators, extruders, fermenters and engine testing beds.

Cost of ownership kept at a minimum

The cooling tower has very low energy consumption compared to other cooling methods. Today's increasing water and

sewage costs make recycling of cooling water more and more cost-effective. Cooling towers from Vestas Industrial Cooling also offer an efficient and low-cost solution for heat re-circulation systems, when removing surplus heat during the summer months.

Longer lifetime through robust design

Vestas Industrial Cooling towers are designed to provide a long and maintenance-free operation. The top, side plates and lower tank are constructed from fibreglass reinforced polyester.

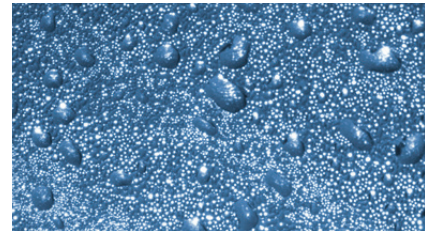

Cooling with cooling towers is based on nature's own resources – water and air

Safe, efficient and environmentally friendly

Pre fab. silencer modules

To comply with a specific noise requirement, the OCT cooling towers can easily be built up with silencers to reduce the noise level. Pre-fabricated modules of silencers are simply to mount upon top, sides and bottom to reduce noise level from the fan, the air intake and water splashing.

OCT	M3	M4	M5	M6	M7	M8	M9
01		✓	✓		✓	✓	✓
02		✓	✓		✓	✓	✓
04	✓	✓	✓	✓	✓	✓	✓
05	✓	✓	✓	✓	✓	✓	✓
06	✓	✓	✓	✓	✓	✓	✓
09	✓	✓	✓	✓	✓	✓	✓
26	✓	✓	✓				✓
35	✓	✓	✓				✓
52	✓	✓	✓				✓

OCT09WB cooling tower with silencer and servicebridge

1. Side silencer to reduce noise from air intake.
2. Noise reduction sections to reduce noise further in sides.
3. Top silencer to reduce noise from fan.
4. Noise reduction sections to put into the top silencer for further noise reduction.
5. End silencer to reduce noise further from both ends.

For further noise reduction, the cooling tower can be built with bottom silencers. The bottom silencer primary reduces the noise from the water.

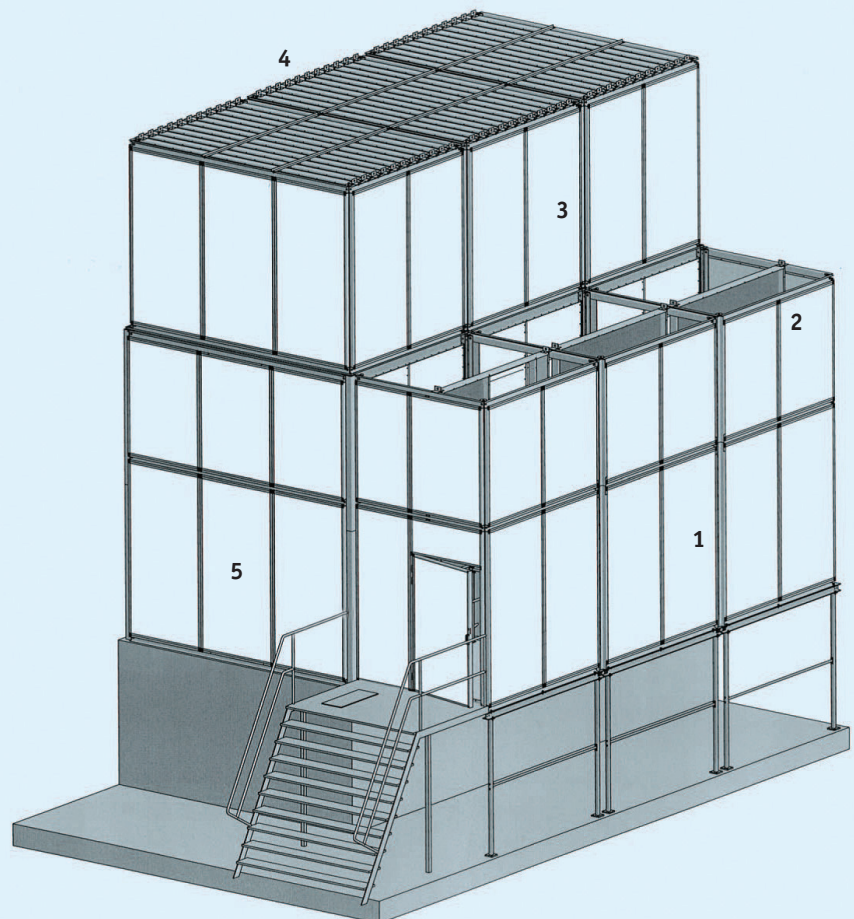

The intake grill made of environmentally friendly polypropylene prevents large particles from being sucked into the cooling towers. Also, it distributes the air correctly.

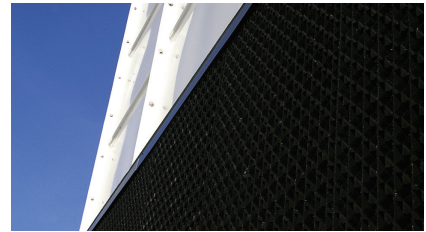

All steel parts are galvanised. The intake is manufactured from polypropylene. In the cooling tower models OCT06 and OCT09, a gear train is used as transmission. In other models, the motor and fan are directly coupled. The cooling liner and the drip tray are made of polypropylene. In the standard version, the cooling liner works with temperature as high as 75°C. We can supply special liners able to withstand operating temperatures of up to 80°C. To sum it up, we produce quality.

No need to interrupt operation

On the inside, the cooling tower is divided into cells with separate fans and water connections. This allows for easy adjustment, as each fan can work independently. The amount of water to be cooled may be varied by switching off the water supply to individual cells. This design ensures greater operating reliability. At the same time, service inspections may take place without the entire installation being shut down. Instead, the cells are "switched off" one by one.

Fast and easy service

Each cell has a full size door for easy access to allow for servicing. Removing a grill gives direct and free access to inspection of level control, the stainless filter at the outlet as well as the overflow. Access to allow cleaning of the lower tank is just as easy.

Plug & Play

The modular construction gives the advantage of a short set-up time, even for large cooling towers. Quite simply, the blocks are placed on top of each other and bolted together. The cooling towers can be packed and delivered in a container.

Low water consumption

Only a small amount of the circulating water needs to be replaced. This is due to evaporation during the cooling process.

Low noise levels

Our cooling towers are designed to produce the lowest possible noise levels considering the high cooling capacity. However, since noise regulations depend on various factors such as area, distance to source of noise and time of day, we are able to lower the cooling tower noise emission to the required level.

Our customers often require special equipment and specific designs adapted to the individual cooling task.

These are examples of special designs:

- Large door for servicing of cooling and fan sections
- Parts made of acid-proof steel (AISI 316) to withstand contact with liquids
- Single-sided intake for connection to air ducts
- Intake with filter for installation in areas with dust, leaves, etc.
- Specific colours matched to surroundings
- Soundproofing according to requirements
- Float control of header tank
- Electronic level monitoring and/or flow control
- Capacity adjustment with multi-thermostat with change-overcycle
- Cooling towers with built-on steel reser-voir, fitted with pumps if required

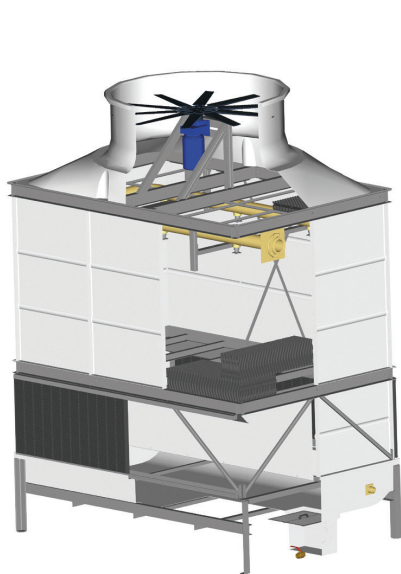

THREE BASIC MODELS FOR DIFFERENT REQUIREMENTS

Vestas Industrial Coolings cooling towers are supplied as three basic models:

Type WA:
Without air-intake, for fitting above water reservoir. Particularly suitable if a large reservoir is already in place, or if special requirements apply to water reservoirs.

Type WB:
Without lower tank, but with intake section. Suitable for installing directly on top of a steel or concrete tank.

Type HB:
With lower tank large enough to make an extra water reservoir unnecessary.

The cooling tower can be individually adapted, e.g. regarding colour, noise level or an access door for inspection and service.

DESIGN DATA:

Wet Bulb Temperature T_{wb} = 21 °C

Max. Inlet Temperature t_i = 80 °C

Min. outlet Temperature = $T_{wb} + 4K$

Natural use of water and air (pr. one cell)

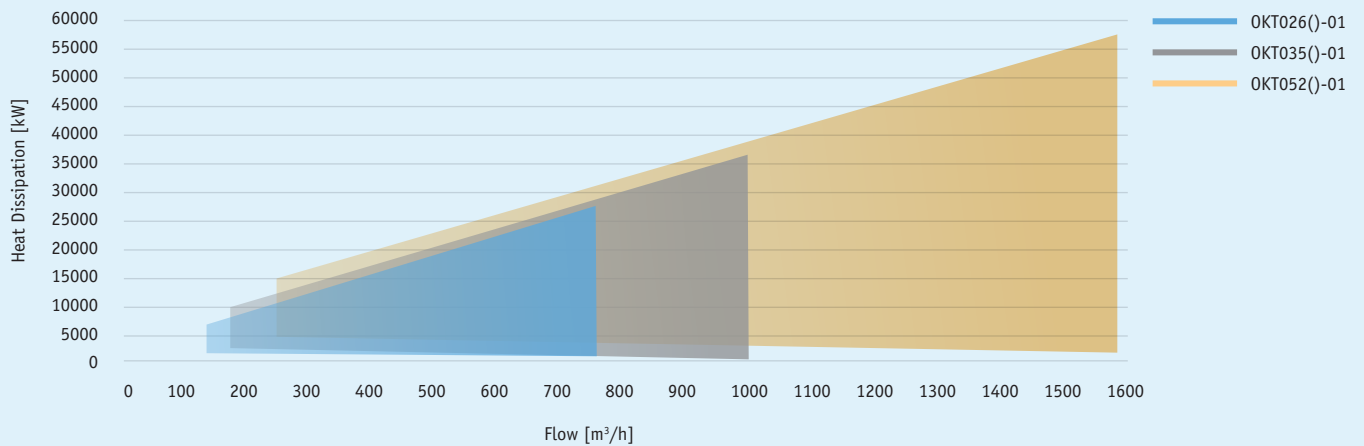
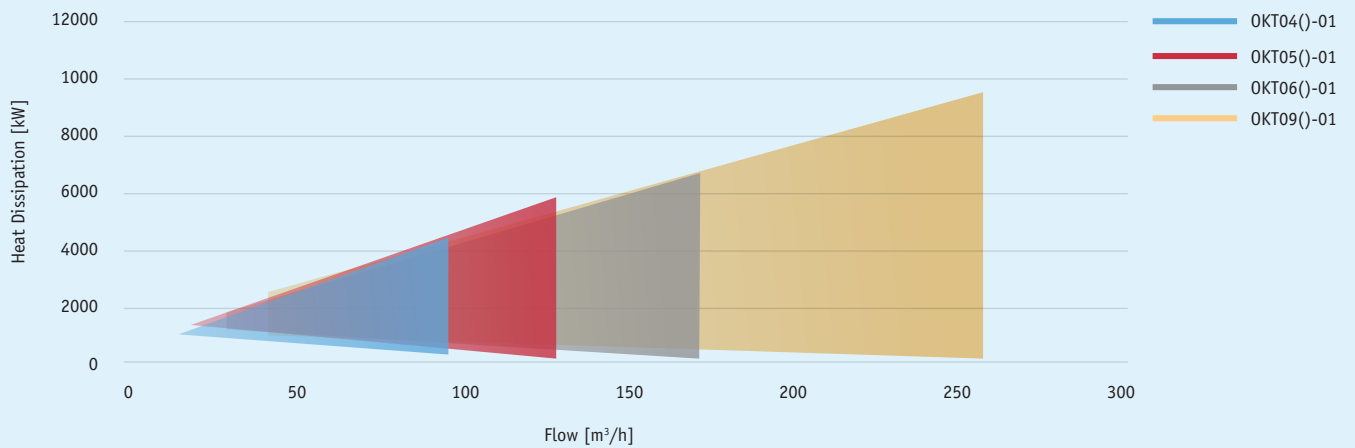
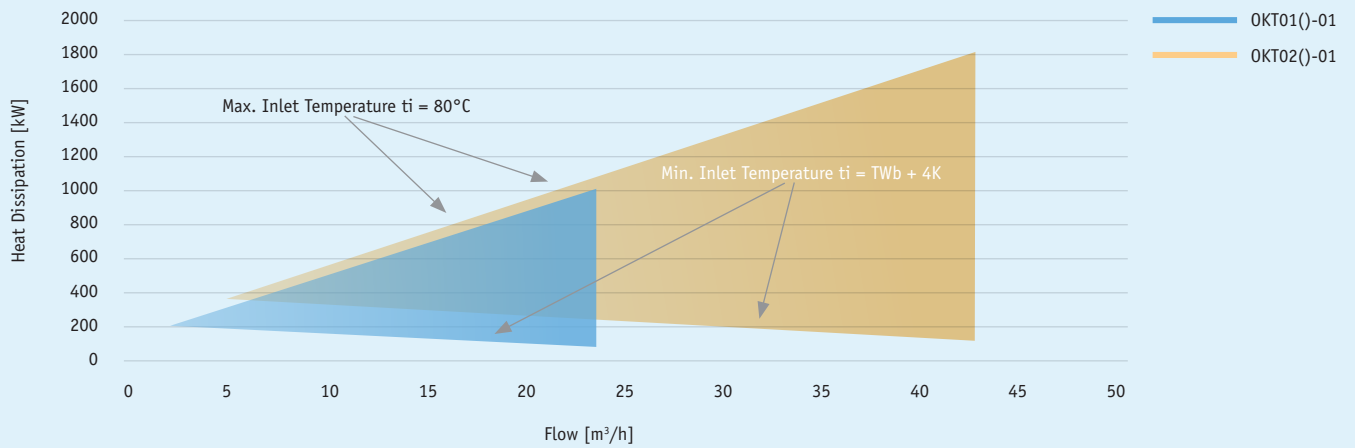

Cooling towers for all your requirements

Type description of Vic standard OCT

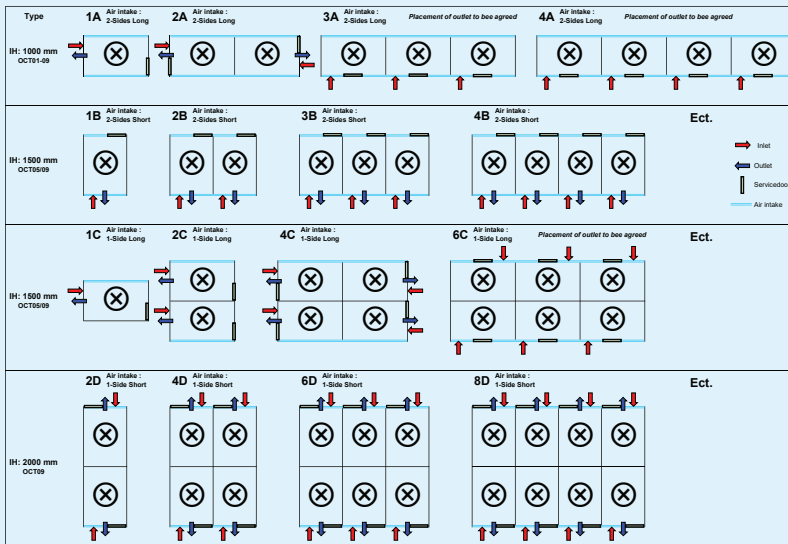

Type description of Vic standard OCT

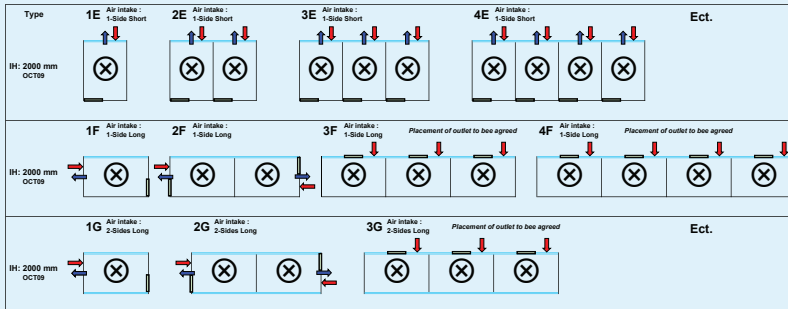

Important : All other types : OCT0x-Spec-x
Placement of inlet, outlet and servicedoor can be re-placed as options!

Choosing the right cooling tower. Vestas Industrial Cooling supplies cooling towers from 10-260 m³/hr cooling water per cell fan. This sketch shows the principal dimensions in mm of the different cooling tower ranges

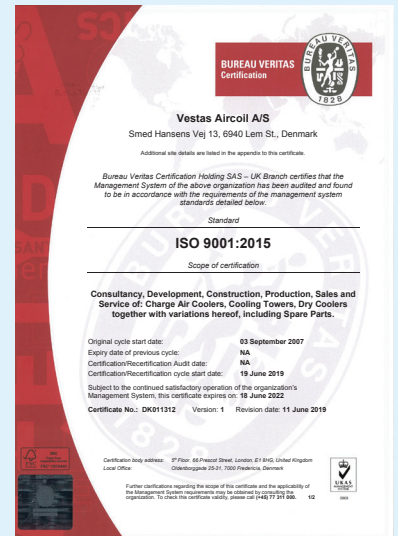

Selected references:



Processor



Processor AB
Box 8011
SE-163 08 SPÅNGA
Sweden

Tel 08-564 722 60
Fax 08-564 722 66
www.processor.se
info@processor.se