



HiFlux Filtration A/S

Micro-line 1050 SS Filters

1 - 1000 micron / 12 - 31 m³/h

HiFlux Micro-line 1050 SS filters in stainless acid-proof EN 1.4404 steel are designed as a compact inline universal filter with many applications.

The filter is supplied as a bag or strainer filter and can be fitted with a magnetic system for efficient retention of magnetic particles.

The filter is designed for a 16 bar design pressure at temperatures of up to 110 °C (water) or according to customers requirements.

The lid is designed in such a way that it can be opened and closed quickly - without using tools, which makes cleaning fast and simple so for the filter to be put back into operation quickly.

In the bag filter version the filter is used where there is a need for reliable fine filtering from 1 micron with a large dirt capacity. Filter bags are available in several material types and filtration ranges (see also data sheet for filter bags).

In the strainer filter version the filter is used where there is a need for a large flow and dirt capacity and a small differential pressure.

As standard the direction of flow is from the inside and out through the filter insert. The dirt is retained in the filter insert, which can be lifted out and cleaned. It is possible to use the strainer filter with reverse flow. This means that the dirt is retained on the outside of the strainer and it is possible to remove the sludge from the filter by fitting a valve into the drain.

The filter can be fitted with a unique magnetic system which makes it possible to collect magnetic particles as small as less than 1 micron. The magnetic insert is designed as an integrate part of the bag insert for simple and fast handling - again without any use of tools - in connection with cleaning.

The magnetic insert is of the HiFlux type which is fitted with Neodymium magnets. In comparison to conventional ceramic magnets provides a magnetic field which is seven times stronger, resulting in significant increases in both efficiency and capacity.

Fittings for suspending the filter can also be supplied as an extra option and should be fitted directly on to the filter housing.

The filter is shown with DN 50, PN16 EN 1092-1 flanges. Other connection types can be supplied in accordance to customers specifications. Standard with R2 nipples.

For other options see also **HiFlux Micro-line 1050**, **HiFlux TS** and **HiFlux TP** filters.



Processor



Processor AB
Box 8011
SE-163 08 SPÅNGA
Sweden

Tel 08-564 722 60
Fax 08-564 722 66
www.processor.se
info@processor.se



Micro-line 1050 SS Filters

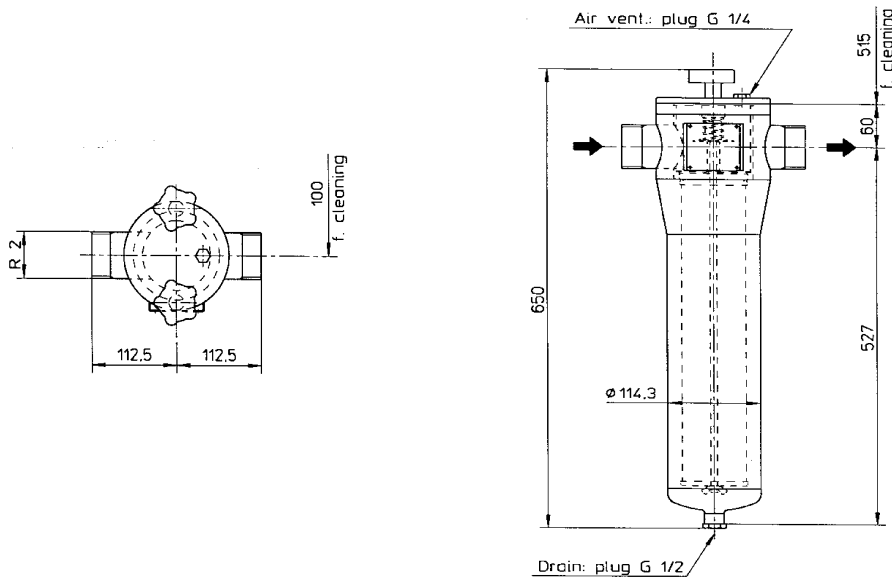

HiFlux Micro-line 1050 SS is manufactured in stainless acid-proof EN 1.4404 steel and accomodates current standards and norms for pressure vessels.

Design pressure: 16 bar
 Test pressure: EN 13445
 Max. differential pressure: 1,0 bar (bag filter), 2,0 bar (strainer filter)
 Max. working temperature: 110° C (water) or according to customer requirements
 Volume: 6 liters
 Weight: 11 kg
 Connection: Nippel R2 EN 10226-1 or flange DN 50, PN16 EN 1092-1

Filter bag (PA): 10-50 micron (max. 120° C)
 Filter bag (PP): 1-5-10-25-50-100 micron (max. 90° C)
 Strainer filter (EN 1.4301): 25-30-50-100-250-500-1000 micron

Magnetic system: HiFlux magnetic insert for both strainer and bag filters

A special strainer or bag for higher temperatures (max. 150° C) is available.

Capacity:
 (at a viscosity of 1 cSt
 and as a pressure filter)

Version	Strainer area Cm ²	Capacity in m3/h at a differential pressure of			
		0,05 bar	0,10 bar	0,15 bar	0,20 bar
Bag filter (1 µm)	1050	12,0	16,0	19,0	22,0
Mag. Bag filter*	1050	13,0	19,0	23,0	26,0
Strainer filter (25 µm)	1050	15,0	22,0	26,0	31,0
Mag. Strainer filter*	1050	16,0	22,0	26,0	31,0

* Optimum retention of magnetic particles as small as 1 micron is achieved by a flow of ≤ 10 m³/h when fitted with the HiFlux magnetic system.