



HiFlux Filtration A/S

PWL & PW Stainless Cartridge Filters

0,2 - 300 micron / 1 - 42 m³/h

HiFlux PWL & PW Cartridge Filters are used where there is a need for reliable and precise fine filtration with a large dirt capacity. The filter housings are designed for a working pressure of 10 bar (PWL 7 bar) and equipped with a simple and secure closing system which makes it quick to change filter cartridges, thereby maximising the time the filters are in operation.

A compact design and the maximum number of built-in filter cartridges ensure the best possible flow and consequently a small differential pressure, long intervals between cartridge changes and lower energy consumption.

The filter housing, which is designed in accordance with the pressure vessel norm, is supplied in stainless acid-proof SUS316 steel.

The filter housings are equipped with supporting tubes to give the cartridges a better tolerance when it comes to differential pressure and temperature.

The filter housings are electropolished to achieve a smooth and uniform surface which is easy to clean and maintain.

Not included in the catalogue is the product range of HiFlux cartridge filters and special filter cartridges for high temperature/pressure uses, e.g. for condensate at 220 °C and 53 bar.

For other options see also **HiFlux TP**, **HiFlux TWP** and **HiFlux Micro-Line filters**.



Processor AB
Box 8011
SE-163 08 SPÅNGA
Sweden

Tel 08-564 722 60
Fax 08-564 722 66
www.processor.se
info@processor.se



PWL Stainless Cartridge Filters

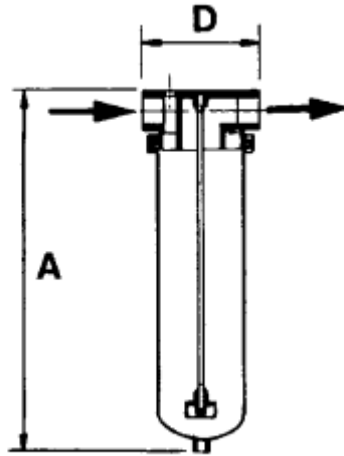

Type	A	D	Cartridge filters	Capacity*	Drain	Air vent.	Connection	Fittings
	mm	mm	D.O.E.	m ³ /h	plug	plug	thread	type
PWL-1	400	95	1 x 10"	1,5	¼" NPT	¼" NPT	R 1	Vee clamp
PWL-2	650	95	1 x 20"	3,0	¼" NPT	¼" NPT	R 1	Vee clamp
PWL-3	900	95	1 x 30"	4,5	¼" NPT	¼" NPT	R 1	Vee clamp

HiFlux standard cartridge filters type PWL are supplied in stainless acid-proof SUS316 steel. The surface is electropolished on the inside and outside.

Design pressure: 7 bar

Test pressure: 10,5 bar

Max. working temperature: 100 °C

Connection: Thread EN 10226

Filter cartridges: See data sheets for filter cartridges

Cartridge types: D.O.E: Cartridges with both ends open

Gasket: EPDM

* The capacity is based on a viscosity of 1 cSt and is not affected by cartridge type, degree of filtration in microns or dirt load.



PW Stainless Cartridge Filters

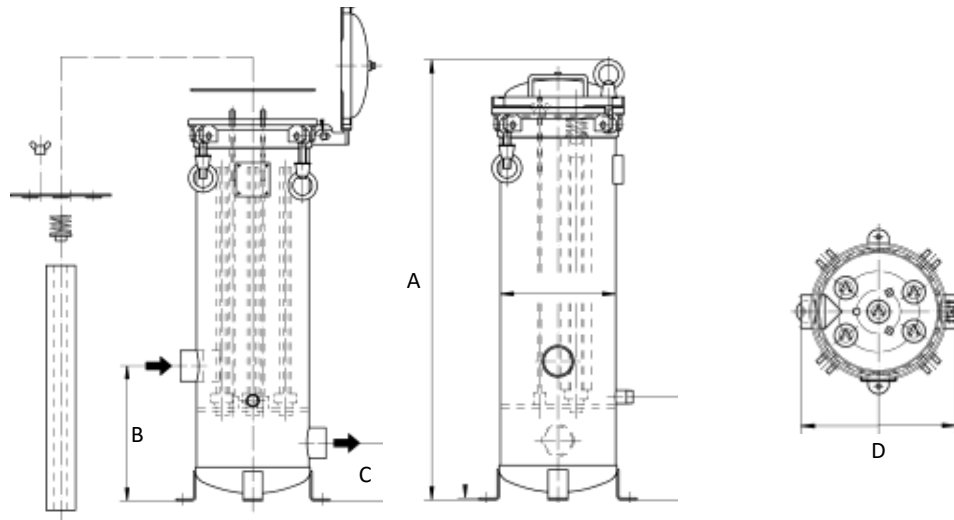

Type	A	B	C	D	Cartridge filters	Capacity*	Drain	Air vent.	Connection	Fittings
	mm	mm	mm	mm	D.O.E.	m ³ /h	thread	plug		No.
PW3-20	885	280	120	336	3 x 20"	9,0	3/4" NPT	1/4" NPT	DN50	4
PW3-30	1140	280	120	336	3 x 30"	13,5	3/4" NPT	1/4" NPT	DN50	4
PW5-20	890	280	120	300	5 x 20"	15,0	3/4" NPT	1/4" NPT	Rp 2	4
PW5-20	890	280	120	358	5 x 20"	15,0	3/4" NPT	1/4" NPT	DN50	4
PW5-30	1145	280	120	358	5 x 30"	22,5	3/4" NPT	1/4" NPT	DN50	4
PW7-20	890	280	120	358	7 x 20"	21,0	3/4" NPT	1/4" NPT	DN50	4
PW7-30	1145	280	120	358	7 x 30"	31,5	3/4" NPT	1/4" NPT	DN80	4
PW7-40	1400	280	120	358	7 x 40"	42,0	3/4" NPT	1/4" NPT	DN80	4

HiFlux standard cartridge filters type PW are supplied in stainless acid-proof SUS316 steel. The surface is electropolished on the inside and outside.

- Design pressure: 10 bar
- Test pressure: 15 bar
- Max. working temperature: 100 °C
- Connection: Thread EN 10226, flange EN 1092-1/01
- Filter cartridges: See data sheets for filter cartridges
- Cartridge types: D.O.E: Cartridges with both ends open
- Gasket: EPDM

*The capacity is based on a viscosity of 1 cSt and is not affected by cartridge type, degree of filtration in microns or dirt load.